

Instructions:

- A. Prior to initial use, fill torch with butane fuel as described below.
B. To fill gas tank, turn unit upside down and firmly push the butane can nozzle into the filling valve

(fig. D) The tank should be filled in approximately 15 seconds. Please allow a few minutes after filling for the gas to stabilize.

C. To ignite torch:

1. Make certain that Hands Free Lever (C) is positioned to the extreme right.
 2. Rotate the gas control knob counterclockwise (left) about 30 degree.
 3. Depress the igniter button (fig B) using thumb. This may require both thumbs since the force required to ignite is high for Child Safety purposes.
 4. With Thumb pushed on igniter button, slide the Hands Free Lever (C) to the left. You may now remove thumb from Igniter Button for Hands Free use.
 5. The flame size can then be adjusted by rotating the gas control knob (fig. A) in either direction.
 6. The flame temperature may be adjusted by rotating the Air Control Ring.
- D. To shut off torch, move Hands Free Lever (C) to the extreme right position and rotate the gas control knob (fig. A) fully clockwise (right).

Features:

State of the art Waterproof Piezo Electronic Ignition system. Large Fuel Tank for 90 minutes use on each filling. Powerful High Output Wind-Resistant flame. Ergonomic designed comfortable grip. Angled nozzle to properly direct flame. Easily refilled with any brand of butane gas. Flame adjustment for the most demanding applications.

Warning:

- Do not touch flame guard while in use or until sufficient time has passed for cooling.
- Do not immerse heated parts or items in water, allow to cool naturally.
- Use only butane gas in the torch.
- Do not use propane gas or any other types of fluids.
- Do not store in a temperature exceeding 40°C /104°F.
- Keep away from eyes at all times.
- Keep this unit out of the reach of children.
- The flame of the torch is nearly invisible in bright light or sunlight.

- Make sure that gas flow is turned off when not in use.

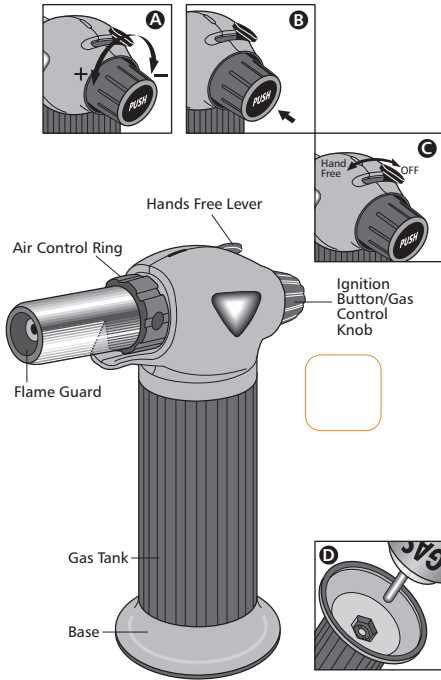

PRO-TORCH™ Model PT-550CR

Dimensions	H-172 mm (6.8inch) L-128 mm (5.0inch) Grip Dia-45 mm(1.78inch) Base-65 mm(2.56inch)
Weight (w / o fuel)	410 g (empty)
Fuel	Butane
Hours of nonstop Burning	90 Minutes (mid. setting)
Flame Temperature	1350°C/2500°F (blue flame)

iroda®

DESIGNED & MANUFACTURED
by PRO-IRODA INDUSTRIES, INC.
www.pro-iroda.com.tw

