

# SOLDERPRO 100

- Automatic Igniting
  - Portable Model
- ## multi-function heat tool

### SPECIFICATIONS

Length: w/cap	233 mm (9.2in)
w/soldering tip	215 mm (8.5in)
Weight (when gas-filled)	142 g
Approximate temperature soldering tip	250~500°C (480~950°F)
Torch	1300°C (2400°F)
Gas container capacity	20 ml
Operating Time (one gas filling)	120 min at mid setting

### Warnings:

- When unit is fueled with flammable gas (Butane) under pressure-use with care.
  - DO NOT expose to heat above +50°C (+120°F) and avoid prolonged exposure to sun.
  - Be extremely careful as torch flame is almost invisible in daylight or strong light.
  - Excessive gas flow, flaming or catalyst pulsing red may occur when the regulator is incorrectly adjusted, i.e., set too high.
  - DO NOT refill, ignite or use near open flame, heater, furnace or combustible materials.
  - KEEP WORK AREA CLEAN. Cluttered areas and benches invite injuries.
  - KEEP AWAY FROM CHILDREN. Visitors should be kept away from work area.
  - STORE WHEN NOT IN USE. Store unit in dry, locked cabinet out of reach of children.
  - USE SAFETY GLASSES TO PROTECT YOUR EYES.
  - DO NOT OVERREACH. Keep proper footing and balance at all times.
  - STAY ALERT. Watch what you are doing. Use common sense. Do not operate unit when you are tired.
  - DO NOT TOUCH THE HEATED TIP OR BARREL OF THE UNIT.
  - DO NOT leave unit unattended when it is operating or still hot.
  - ALWAYS BE SURE THE UNIT IS COOL BEFORE STORING.
  - DO NOT REPLACE CAP WITHOUT SWITCHING UNIT OFF AND ENSURING TIP HAS COOLED.
  - Ensure flame is extinguished before storing unit.
  - USE ONLY IN WELL VENTILATED AREA.
  - DO NOT ATTEMPT TO READJUST OR REPAIR. UNIT IS NOT USER SERVICEABLE.
- READ ENCLOSED INSTRUCTION MANUAL PRIOR TO USE.  
• BUTANE NOT INCLUDED.



### HOW TO USE SOLDERPRO 100

#### REFUELING

- 2.1 Make sure ON / OFF switch is at "OFF" position before filling.
- 2.2 Adaptors are not normally required when refilling.
- 2.3 To refill hold refill can as pictured (fuel transfer is dependent upon gravity).
- 2.4 Stop filling when overflow gas.

#### IGNITION SEQUENCE-1

- 3.A Lift up ON/OFF IGNITION SWITCH to the "ON" position to start the flow of gas.
- 3.B Push the switch upward toward tip to the maximum point to ignite then release the switch back to "ON" position to stay on.
- 3.C To turn off, slide the ON / OFF ignition switch downward toward the gas control lever.

#### IGNITION WARNINGS

- 3.D Do not touch Tip, Tip Housing or Knurled Nut while igniting.
- 3.E Do not ignite the unit when "Tip Assembly" is not screwed on.

#### HOW TO USE SOLDERING IRON

- 3.1.1 Be sure the hot air exhaust hole is positioned upward as pictured.
- 3.1.2 Set gas control level at **mid** position.
- 3.1.3 Push the ON / OFF ignition switch slowly upward toward tip to the max. point and release the switch. (same as 3A & 3B)
- 3.1.4 You may hear the sound of gas flowing and then the tip housing window will glow orange after 1 or 2 seconds. If not, repeat #3.1.3
- 3.1.5 Tip temperature can be changed by adjusting the gas control lever.
- 3.1.6 To turn off, Same as 3.C It is not necessary to move the gas control lever after the unit is turned off.

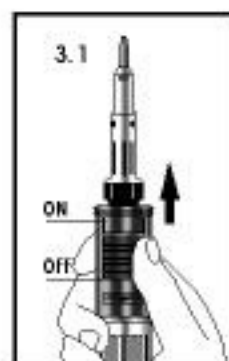
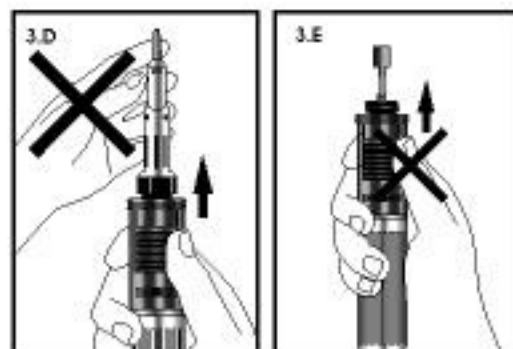
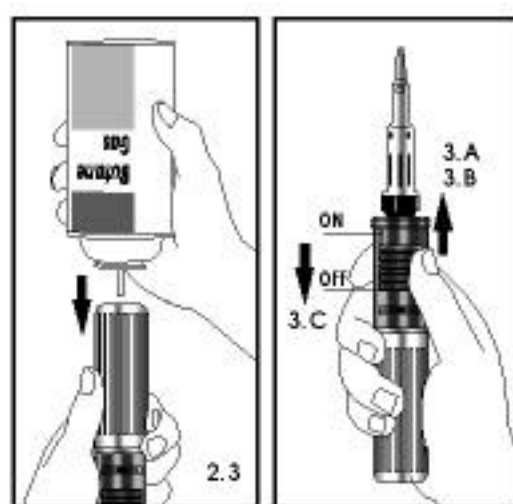

#### HOW TO USE BLOW TORCH

- 3.2.1 Remove tip and tip housing by untightening Knurled Nut.
- 3.2.2 Mount the same tip housing in place without tip.
- 3.2.3 Ignite gas by means of on/off ignition switch (Same as 3.A & 3.B).
- 3.2.4 Adjust flame length. Do not adjust to maximum length as gas may flare-up and turn off.
- 3.2.5 To shut off the unit, refer to (3.1.6)

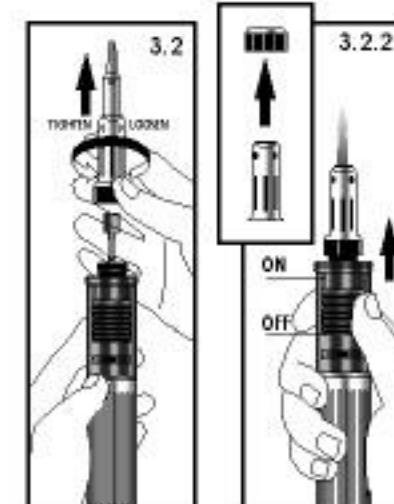

#### HOW TO USE HEAT BLOW TIP

- 3.3 Same as soldering tip.

#### HOW TO USE HOT KNIFE TIP

- 3.4 Same as soldering tip.

#### ADJUSTMENT

- 4.1 The tip temperature can be adjusted by turning the GAS CONTROL LEVER observing the - + signs on the body.
- 4.2 Ideally set the GAS CONTROL LEVER to **mid** position when soldering or brazing.
- 4.3 It is not necessary for the catalyst inside the tip to glow bright red to achieve satisfactory soldering temperatures. Experience will dictate the adjuster setting required.



#### CHANGING TIPS

- 5.1 Be sure the tip has cooled before removal.
- 5.2 The catalyst seen through the Hot Air Exhaust Hole of the soldering tip is very delicate and will not sustain mechanical abuse without serious damage.
- 5.3 The soldering tip is easily removable allowing the installation of other style tips or the replacement of a worn tip. After the soldering tip is cool, simply unscrew it with a counterclockwise motion. Be careful not to overtighten as this could damage the nozzle assembly and thread in the body.

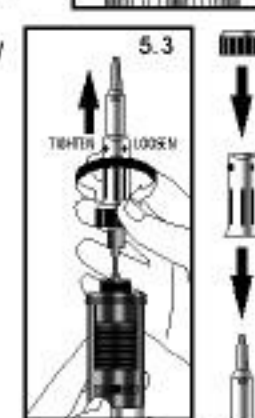

#### CLEAN OR REPLACE ORIFICE ASSEMBLY

- 6.1 Remove soldering tip and flame collar in the normal manner.
- 6.2 While holding the torch straight up in the vertical position, unscrew Nozzle Assembly (A) from the Torch Body (C). You may have to use a pliers or other tool to start unscrewing. Do not grasp and turn the Ceramic Head (D).
- 6.3 Carefully remove Orifice Assembly (B) by lifting out of torch body. NOTE THAT THE SHORTER SIDE OF ORIFICE ASSEMBLY FITS INTO TORCH BODY.
- 6.4 Soak Orifice Assembly in Naptha or other similar solvent for approximately 5 minutes.
- 6.5 Replace clean (or new) Orifice Assembly remembering to insert the SHORTER SIDE INTO TORCH BODY.
- 6.6 Replace Nozzle Assembly and hand tighten or tighten gently with a pliers grasping the shank of the Nozzle Assembly.

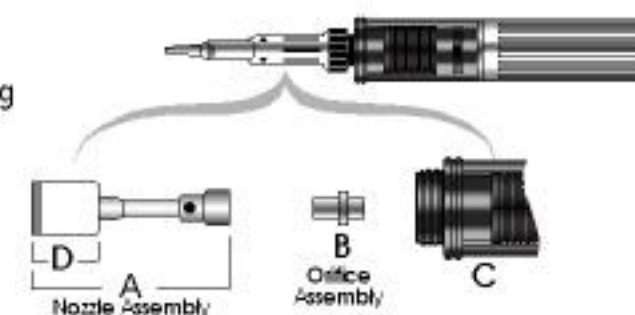

#### REPLACE CAP

- 7.1 When replacing cap please refer as shown picture 7.1

#### CLEANING

- 8.1 Use only mild soap and a damp cloth to clean the housings of the tool. Many household cleaners contain chemicals which could seriously damage the plastic. Also do not use gasoline, turpentine, lacquer or paint thinner, dry cleaning fluids or similar products. Never let any liquid get inside the tool; never immerse any part of the tool into a liquid.



#### IMPORTANT NOTE:

THIS TOOL HAS BEEN ESPECIALLY DESIGNED FOR USE WITH 100% BUTANE GAS. ANY OTHER BUTANE-PROPANE MIX OR OTHER FUEL GASES COULD CREATE MUCH HIGHER TEMPERATURES AND INDUCE 'FLARE UP' AT THE TIP EXHAUST SLOTS.

#### TROUBLESHOOTING

9. To reduce the risk of personal injury, property damage, or damage to your **SOLDERPRO 100**, do not attempt to repair the unit body.

PROBLEM	PROBABLE CAUSE	HOW TO CORRECT
9.1 Does not ignite	a. Empty tank b. Too high or low fuel pressure c. Push on/off ignition switch too fast. d. Clogged orifice assembly	a. Refill with butane fuel b. Adjust control lever to a higher or lower position. c. Re-read "How to use as a soldering iron" d. Clean or replace with new orifice assembly
9.2 Low gas pressure or low flame	a. Clogged orifice assembly b. Cold fuel c. Low fuel	a. Clean or replace with new one. b. Hold body in hands to allow unit to warm up. c. Refuel
9.3 Tip does not heat up	a. Used-up catalyst b. Insufficient fuel pressure c. Clogged orifice assembly	a. Replace with new tip. b. Adjust control lever to a higher position. c. Clean or replace with new one.

#### BASIC TIPS

